



CORPORATION OF HARPERS FERRY

Town Council

MINUTES

Special Meeting

Monday, 26 October 2020

5:30 p.m.

Town Hall • 1000 Washington Street, Harpers Ferry, West Virginia 25425 • VIA ZOOM

Called to order at 5:30 p.m. by Mayor Bishop. Due to the COVID-19 pandemic, this meeting was conducted through Zoom and live-streamed on social media, in compliance with the State's emergency guidance on the Open Governmental Meetings Act.

Member	Title	Status
Wayne Bishop	Mayor	Present
Kevin Carden	Recorder	Present
Barbara Humes	Councilmember	Present
Hardwick S. Johnson, Jr.	Councilmember	Present
Christian Pechuekonis	Councilmember	Present
Jay Premack	Councilmember	Present
Nancy Singleton Case	Councilmember	Present

1. Discussion and action on S. McIntyre / C. Gauthier Zoning Compliance Permit Application; request to use and temporarily improve the Cambridge Street right-of-way, north of W Ridge Street.

Motion	<p>Motion that pursuant to Harpers Ferry Ordinance Article 909.03, the Town Council issue a permit granting the use of the Cambridge Street public right-of-way (ROW), that portion north of West Ridge Street. The Town Council further agrees to permit the temporary improvement of said public ROW, accepting the Planning Commission's recommended conditions voted upon on July 30, 2020, the Town Council's recommended conditions voted upon on September 2, 2020, and further modified as follows:</p> <ol style="list-style-type: none">(1) In granting use, the public ROW improvement will be for access only; is for public use and is not a private drive; and no private or public parking on the improved public ROW is permitted;(2) Initial cost and continued maintenance costs, to include winter maintenance, are to be borne by the property owner, as permit applicant, until such time as the Corporation of Harpers Ferry should vote otherwise, relieving the property owner / applicant of said maintenance cost(s) obligation; with said vote occurring upon the issuance of a final occupancy permit for a new home to be permitted and constructed on Lot 9A, Block "O", Harpers Ferry, or two years
---------------	---

	<p>from the date of issuance of this permit, whichever occurs first; notwithstanding, that the Corporation of Harpers Ferry may, at its discretion, exercise its legal right to reassume maintenance of the right-of-way at an earlier date, if deemed necessary;</p> <p>(3) The public ROW improvement must be designed in such a manner as to prevent soil accumulation on the road surface, and prevent sediments and runoff drainage from impacting neighborhood properties and the adjacent intermittent streambed;</p> <p>(4) The public ROW improvement is to extend no further than 200 feet from the north paved edge of West Ridge Street and be a width of 12 feet across, which excludes the sloped drainage areas to each side; be graded down to a minimum of six inches in depth; and positioned with one edge at the approximate future centerline of the ROW, with the 12-foot width of the road on the east side of the ROW, adjacent to the property owner's / applicant's property, allowing for future public utility easements to the west of the new road;</p> <p>(5) The public ROW improvement must be constructed of pervious material, specifically CR6 or CR8 roadbed gravel;</p> <p>(6) With exception of the width, the public ROW improvement must be constructed to the Typical Roadway Section Without Curb and Gutter, contained within the City of Charles Town's design standards, "Appendix A: Typical Roadway Sections", page 4 (attached to the official minutes for this meeting);</p> <p>(7) Prior to commencing construction, the owner / applicant must provide, and submit for review to the Town, evidence of insurance coverage for the contracting company responsible for the road construction project. The contractor's insurance company must provide a policy reflecting a minimum limit of \$1 million and the insurance company's declaration sheet, naming the Corporation of Harpers Ferry as an additional insured on the policy; and</p> <p>(8) Prior to commencing construction, the owner / applicant must provide, and submit for review to the Town, evidence of a Performance Bond in the sum of \$2,500, which secures the faithful performance by the contractor of completion of the road construction project. The bond must be issued by a surety authorized to do business in the State of West Virginia, contain the original notarized signature of an authorized officer of the surety company, be unconditional, and remain in force during the entire term of the road construction project. The bond shall be released if the contractor promptly and faithfully performs all terms and conditions as set forth in this permit, as determined upon final inspection, and the bond release form is executed by the Corporation of Harpers Ferry.</p> <p>(ROLL CALL VOTE REQUESTED)</p>
Motion by	Nancy Case
Second	Hardy Johnson
YES	Humes, Premack, Johnson, Pechuekonis, Case, Carden, Bishop
NO	<i>None</i>
Result	MOTION APPROVED

Motion to adjourn by Jay Premack, second by Christian Pechuekonis. Meeting adjourned at 7:24 p.m.

The above minutes are true and correct, as approved.

Mayor: _____ Date: _____

Recorder: _____ Date: _____

Appendix A

Typical Roadway Sections

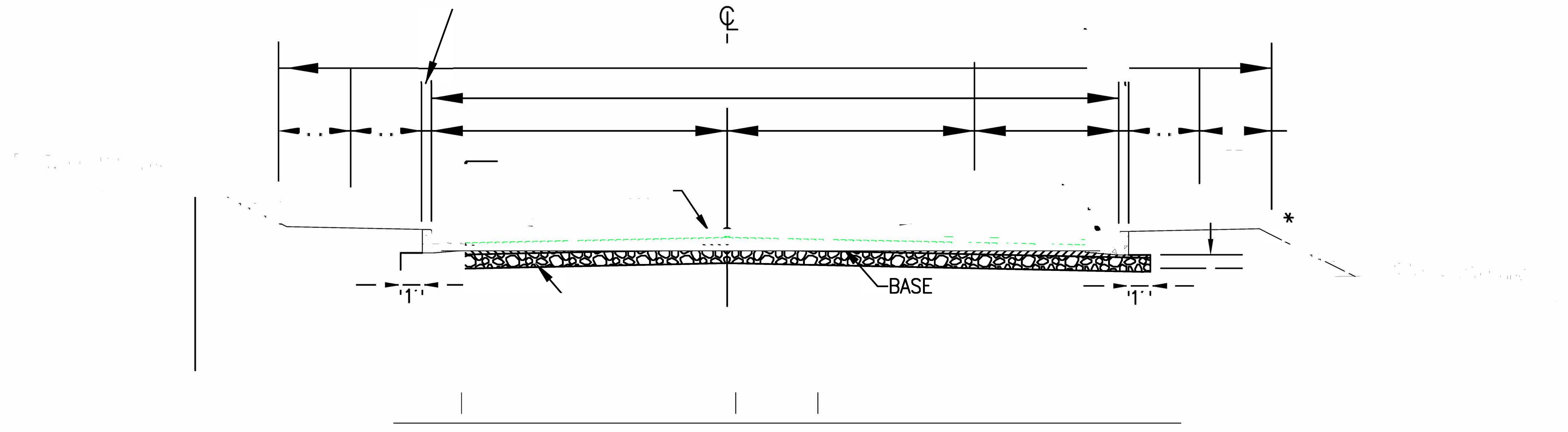

*

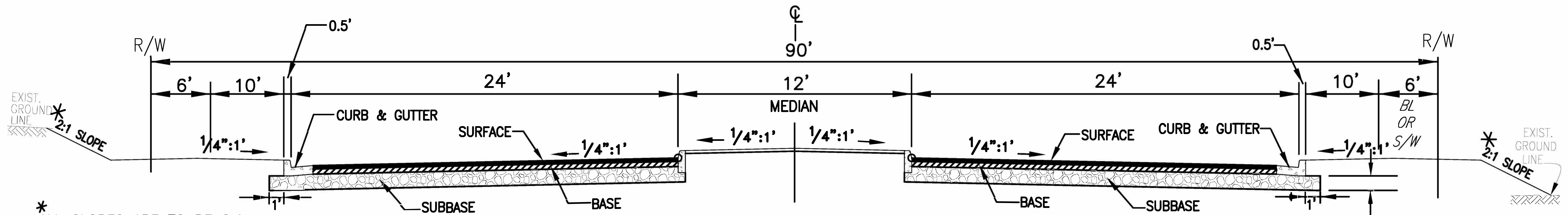

* ALL SLOPES ARE TO BE 2:1 OR FLATTER UNLESS SPECIFICALLY APPROVED BY THE DIRECTOR OF PUBLIC WORKS.

EXTENSION OF SUBGRADE OR 4" MIN., WHICHEVER IS GREATER

TYPICAL ROADWAY SECTION WITH CURB AND GUTTER

TYPICAL SECTION - PRIMARY STREET

City of Charles Town

