



CORPORATION OF HARPERS FERRY

Town Council

MINUTES

Special Meeting **Wednesday, 2 September 2020** **5:00 p.m.**
Town Hall • 1000 Washington Street, Harpers Ferry, West Virginia 25425 • VIA ZOOM

Called to order at 5:00 p.m. by Mayor Bishop. Due to the COVID-19 pandemic, this meeting was conducted through Zoom and live-streamed on social media, in compliance with the State’s emergency guidance on the Open Governmental Meetings Act.

Member	Title	Status
Wayne Bishop	Mayor	Present
Kevin Carden	Recorder	Present
Barbara Humes	Councilmember	Present
Hardwick S. Johnson, Jr.	Councilmember	Present
Christian Pechuekonis	Councilmember	Present
Jay Premack	Councilmember	Present
Nancy Singleton Case	Councilmember	Present

1. Discussion and action on S. McIntyre / C. Gauthier Zoning Compliance Permit Application; request to temporarily improve Cambridge Street right-of-way north of West Ridge Street.

Motion	<p>Motion that pursuant to Harpers Ferry Ordinance Article 909.03, the Town Council issue a permit granting the use of the Cambridge Street public right-of-way (ROW), that portion north of West Ridge Street. The Town Council further agrees to permit the temporary improvement of said public ROW, accepting the Planning Commission’s recommended conditions voted upon on July 31, 2020, further modified as follows. The public ROW improvement:</p> <ol style="list-style-type: none">(1) In granting use, shall be for access only, is for public use and is not a private drive, and no private parking on the improved public ROW is permitted;(2) Initial cost and continued maintenance costs are to be borne by the property owner, as permit applicant, until such time as the Corporation of Harpers Ferry should vote otherwise, relieving the property owner / applicant of said maintenance cost(s) obligation;(3) Must be designed in such a manner as to prevent soil accumulation on the road surface, and prevent sediments and runoff drainage from impacting neighborhood properties and the adjacent intermittent stream bed;
---------------	--

	<p>(4) Shall extend no further than two hundred feet (200') from the north paved edge of West Ridge Street, and be a width of twelve feet (12') across;</p> <p>(5) Must be constructed of pervious material, specifically CR6 or CR8 roadbed gravel;</p> <p>(6) With exception of the width, must be constructed to the Typical Roadway Section Without Curb and Gutter, contained within Charles Town's design standards, "Appendix A: Typical Roadway Sections", page 4 (attached to the official minutes for this meeting);</p> <p>(7) Must provide a current survey of Cambridge Street ROW that demonstrates the road design will fall within the center of the ROW, allowing for future public utility easements to the east and west of new road; and</p> <p>(8) Final permit terms and issuance are subject to legal review, understanding that time is of the essence.</p> <p>(ROLL CALL VOTE REQUESTED)</p>
Motion by	Nancy Case
Second	Kevin Carden
YES	Humes, Johnson, Pechuekonis, Premack, Case, Carden, Bishop
NO	<i>none</i>
Result	MOTION APPROVED

2. Discussion and action to retain counsel to draft employee letter.

Three attorneys who specialize in employment law were considered regarding two employment-related issues. One of those attorneys stated a conflict of interest; another may have a conflict of interest as well. Mr Greg Bailey, the third attorney, has verbally agreed to draft a letter for the Town. The consensus of the Town Council was to move forward with using Mr Bailey for this legal work, as a "one-off" at an hourly rate.

Motion to adjourn by Jay Premack, second by Christian Pechuekonis. Meeting adjourned at 6:31 p.m.

The above minutes are true and correct, as approved.

Mayor: _____ Date: _____

Recorder: _____ Date: _____

Appendix A

Typical Roadway Sections

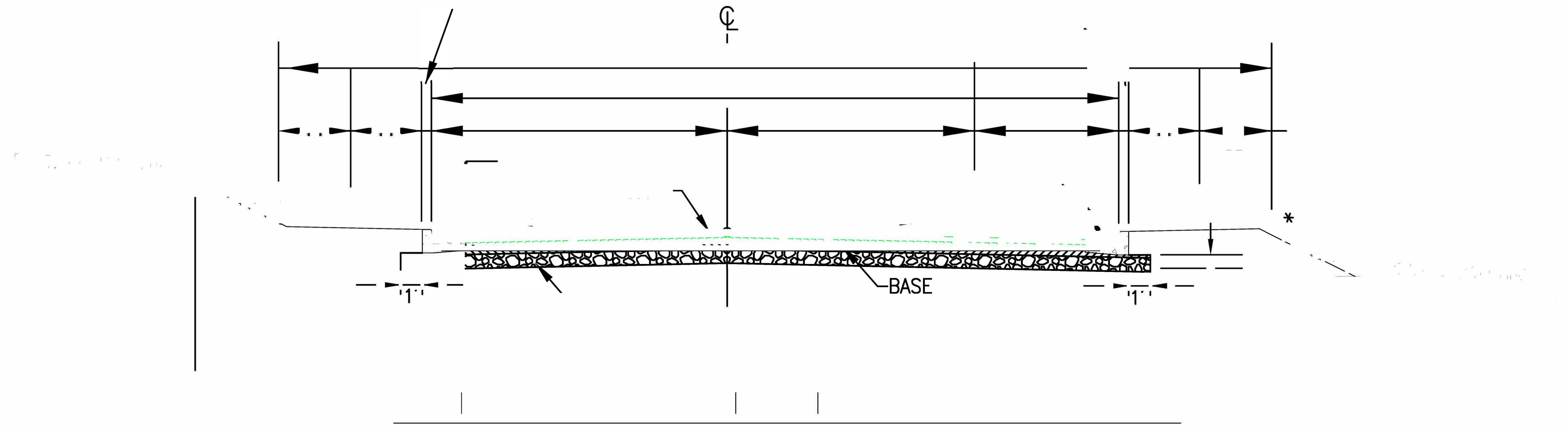

*

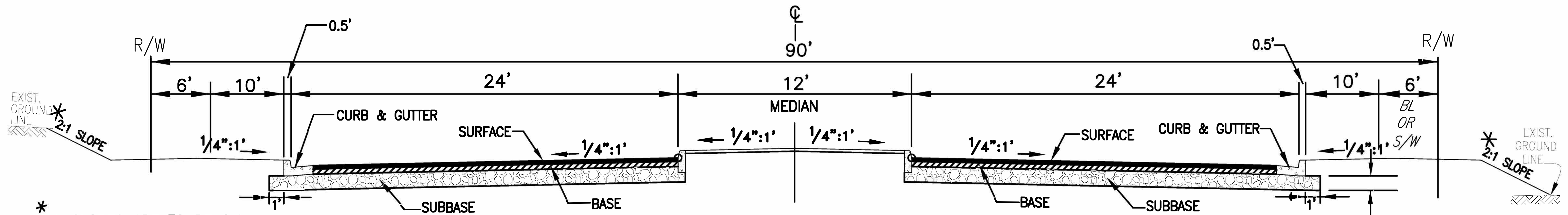

* ALL SLOPES ARE TO BE 2:1 OR FLATTER UNLESS SPECIFICALLY APPROVED BY THE DIRECTOR OF PUBLIC WORKS.

EXTENSION OF SUBGRADE OR 4" MIN., WHICHEVER IS GREATER

TYPICAL ROADWAY SECTION WITH CURB AND GUTTER

TYPICAL SECTION - PRIMARY STREET

City of Charles Town

